



APPLICATION AREAS

- WASTE WATER TREATMENT
- TEXTILE
- PACKAGING
- CHEMICAL INDUSTRY
- AUTOMOTIVE
- FOOD INDUSTRY
- PAINT INDUSTRY

ADVANTAGES

- 1) Solid particles may pass through the pump.
- 2) Maintenance cost is low.
- 3) Liquid flow rate can also be adjusted when the air inlet pressure of the pump is adjusted.
- 4) The pump's air valve and pilot valve repair kits can be repaired without disassembling the pump.
- 5) It has the feature of working dry.
- 6) The suction depth of this pump is 1 m.

PUMP TECHNICAL SPECIFICATIONS

- Max. Capacity** : 16 l/min
- Fluid Inlet-Outlet** : 1/4"
- Max. Fluid Discharge** : 7 bar
- Body Material** : Polipropilen - PVDF
- Air Inlet Size** : 1/4"
- Solid Particle Size** : 1 mm
- Dry Suction Depth** : 1m - 1,5 m
- Max Air Pressure** : 7 bar
- Diaphragm Options** : Santoprene, Neoprene, Buna-N, EPDM, Teflon, Viton
- Ball Options** : Santoprene, Neoprene, Buna-N, EPDM, Teflon, Viton
- Ball Seat Options** : Santoprene, Neoprene, Buna-N, EPDM, Teflon, Viton

DIAPHRAGM PUMPS PERFORMANCE CURVES

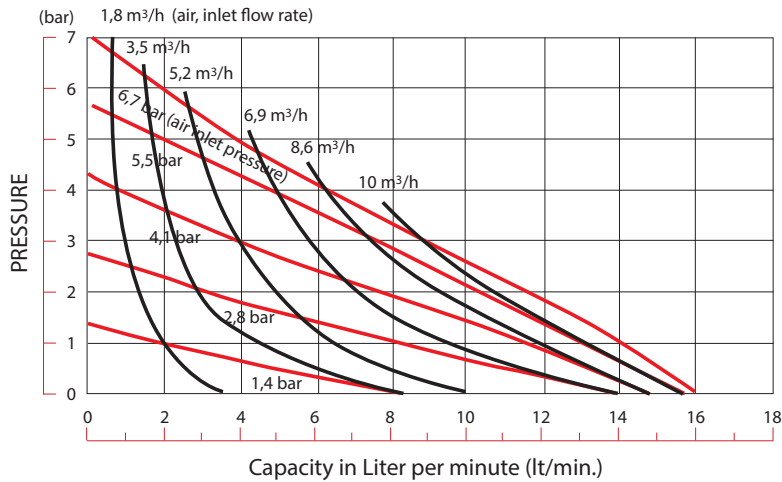

PUMP EXTERNAL DIMENSIONS

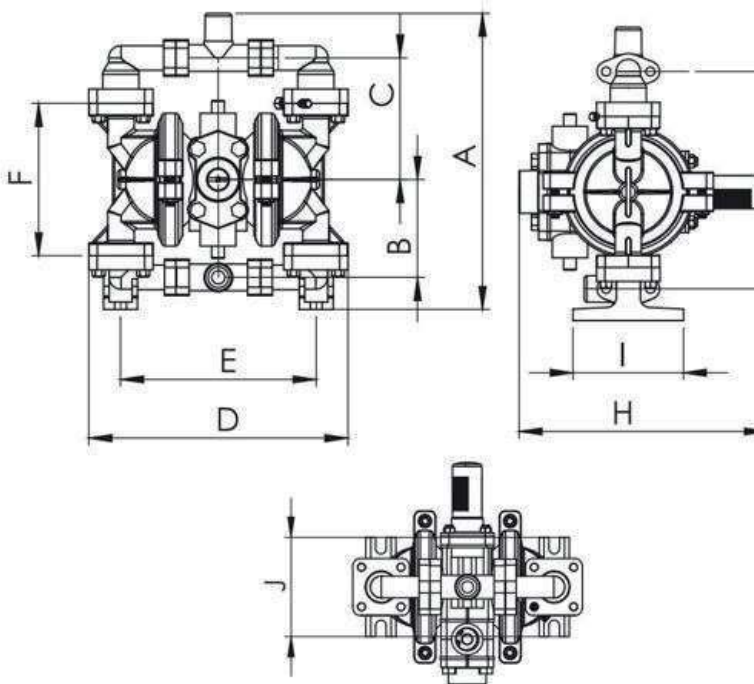

A	B	C	D	E	F	G	H	I	J
212	70	87	186	140	109	157	180	80	80