



APPLICATION AREAS



- WASTE WATER TREATMENT
- MARINE
- TEXTILE
- MACHINE-AUTOMATION
- PACKAGING
- DEFENSE INDUSTRY
- AUTOMOTIVE
- PETROL AND OIL
- FOOD INDUSTRY
- CERAMIC INDUSTRY
- PAINT INDUSTRY
- MEDICAL INDUSTRY
- MINING - ENERGY

ADVANTAGES



- 1) Solid particles may pass through the pump.
- 2) Maintenance cost is low.
- 3) Liquid flow rate can also be adjusted when the air inlet pressure of the pump is adjusted.
- 4) The pump's air valve and pilot valve repair kits can be repaired without disassembling the pump.
- 5) It has the feature of working dry.
- 6) The suction depth of this pump is 6 m.

PUMP TECHNICAL SPECIFICATIONS



- Max. Capacity** : 560 l/min
- Fluid Inlet-Outlet** : 2"
- Max. Fluid Discharge** : 7 bar
- Body Material** : Cast Iron
- Air Inlet Size** : 3/4"
- Solid Particle Size** : 6 mm
- Dry Suction Depth** : 6 m
- Max Air Pressure** : 7 bar
- Diaphragm Options** : Santoprene, Neoprene, Buna-N, EPDM, Teflon, Viton
- Ball Options** : Santoprene, Neoprene, Buna-N, EPDM, Teflon, Viton
- Ball Seat Options** : Santoprene, Neoprene, Buna-N, EPDM, Teflon, Viton

DIAPHRAGM PUMPS PERFORMANCE CURVES

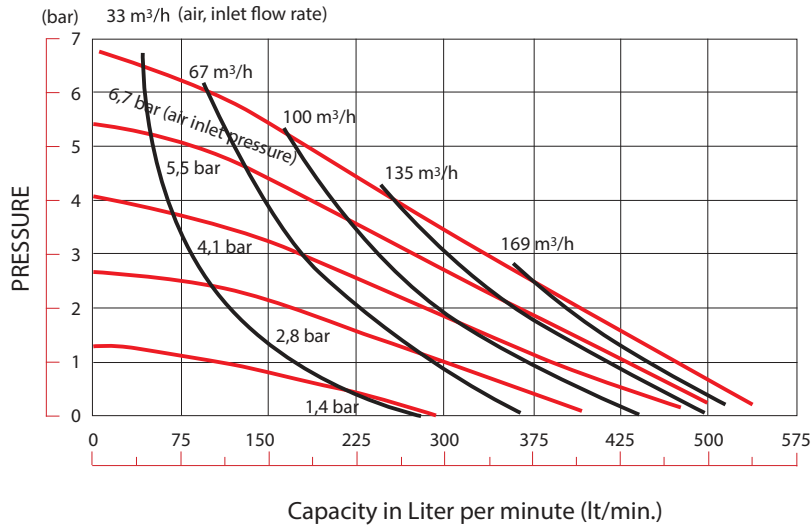

PUMP EXTERNAL DIMENSIONS

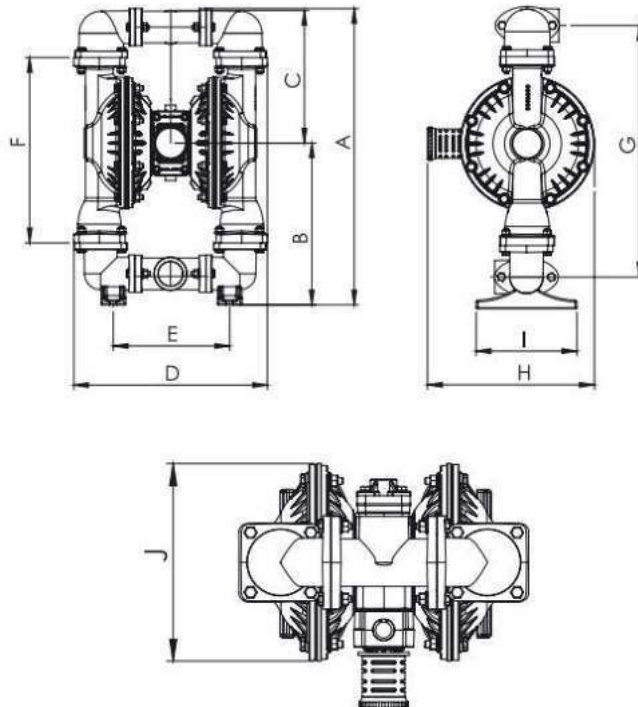

A	B	C	D	E	F	G	H	I	J
669	365	299	438	263	418	556	370	223	298